

# BALL VALVE



## VALVE SOLUTIONS for Corrosive Applications



**UNPPolyvalves**

Manufacturer of PFA/FEP/PTFE Lined & Plastic Valves,  
Pipes & Pipe Fittings



# VALVE SOLUTIONS for Corrosive Applications



## About Us

UNP Polyvalves is manufacturing Corrosive application valves since 1988.

UNP started with all plastic Valves with limited size options, today has a complete range of corrosive application valves in both options of Solid plastic Valves and Lined Valves. UNP now has in it's range Ball, Plug, Butterfly, Diaphragm Valves, Non-return Valves, Strainers, Sampling Valves, Pipes and Pipe fittings. This completes range of complete piping solution in corrosive applications.

UNP has most modern facility situated at Por with latest moulding technology and highest moulding capacity to manufacture lined valves as large as 24" with Injection moulding machines of largest capacity in the country.

Envisioned for quality and reliability, UNP Polyvalves aims for highest level of Customer satisfaction through its solutions with the commitment for excellence in all spheres of business.

UNP Polyvalves possesses live skill sets headed by highly knowledgeable, technically

experienced entrepreneurs. These experts lead and guide their team with a great vision to achieve high quality standards to make products for its high performance and unmatched quality.

UNP Polyvalves, over all these years has been dealing with almost all chemical process industries in Chlor Alkali, Chemical, Pharmaceutical, Mining, Refineries etc., in India and exporting to 35+ countries in the world including market such as USA, Europe, Latin America, Africa, Russia, South East Asia, Australia etc. . . .

## Achievements

UNP Polyvalves through its technical expertise and involvement in knowing physical process parameters could help resolving corrosion problems related to valves and piping system in Industries such as Chlor Alkali, CRM in Steel Industries, Chemical injection skids for Oil and Gas and many more chemical plant across the world. UNP today has approvals from leading consultants such as UHDE, Jacobs Engineering, Mott McDonald, Toyo Engineering, Fluor Daniel, TUV, EIL etc., and have worked for their prestigious projects.

## PRODUCT FEATURES AND OPTIONS AVAILABLE

- UNP offers both Reduced Port and Full Port Design Ball Valves.
- UNP has floating Ball Design for Reduced Port and Ball & Stem Integral design for Full Port Ball Valves.
- UNP offer Chevron packings (Sintered Packings) for both reduced Port and Full Port Valves and Valves are subjected to Helium Leak test in case if the same is required.
- UNP lining is anchored with dove tail groove and makes it's valve suitable for both Pressure and Vacuum Applications.
- UNP offers all metal components in investment castings, ensuring intact and homogeneous lining and having an overall even thickness of lining at intricate contours.
- UNP uses virgin raw materials such as PFA from Dupont or Dyneon and specific grades are used which are high purity grade, enables use of it's valves even in Pharma and food industries.
- UNP can offer flange dimensions in DIN, ANSI and JIS standards.
- UNP Valves are all with ISO mounting pad design, enables mounting of actuators very easy.
- UNP does lining of all Valves by latest injection molding process and not by transfer molding process makes its lining more compact and reliable.
- UNP subjects it's 100% valve quantity produced to both Hydro and Pneumatic Test ensuring 100% reliability for performance of valves under pressure.
- UNP is an ISO 9001:2008 company and is having CE certificate for all its Lined Ball Valves both reduced port and full port design under PED 1128.
- UNP provides all lining materials for corrosive applications such as PFA, FEP, PVDF, ETFE, ECTFE and PPH.
- UNP standard body casting material is ASTM A 216 GR. WCB and upon requirement can also provide ASTM A 351 GR. CF 8 or CF 8 M / ASTM A 890 GR. 4A (CD3MN) / Super Duplex.
- UNP provides Antistatic PFA lined Valves in grade C 980 of Dupont or 8502 ESDZ of Dyneon as just the grounding spring device can not conduct static charge from inside of the valve as normal grade of PFA is non-conductive liner in valve.

# PFA LINED BALL VALVE

## SIDE SPLIT - FULL PORT - LEVER OPERATED - ANSI

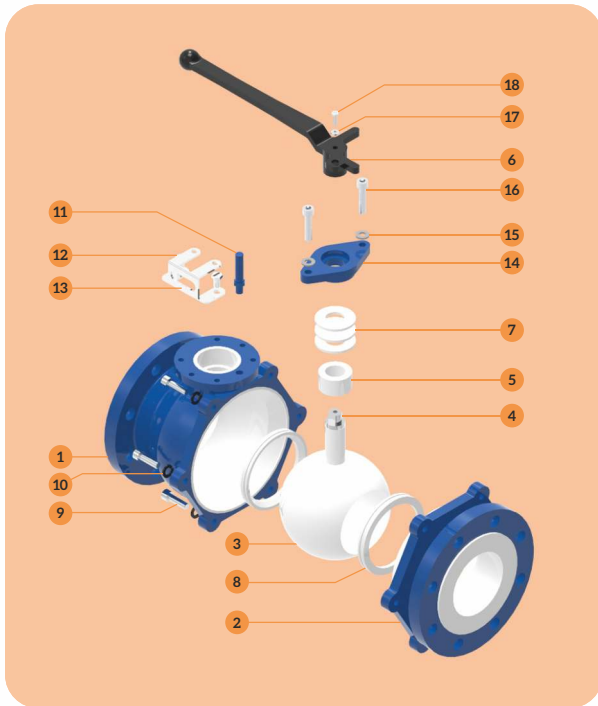

### PART LIST

PART NO.	DESCRIPTION	MATERIAL OF CONSTRUCTION	QTY.
1	Body	ASTM A 216 GR. WCB + PFA LINED	1
2	Side Piece	ASTM A 216 GR. WCB + PFA LINED	1
3	Ball	CF8 INSTERTED PFA LINED	1
4	Stem Integral To Ball	CF8 + PFA LINED	1
5	Bush	PTFE	1
6	Handle	CS EPOXY PAINTED	1
7	Chevron	PTFE	3 - 6
8	Seat	PTFE	2
9	Allen Bolt For Body	ASTMA A 193 GR.B7	4 - 8
10	Allen Bolt Washer	STEEL	4 - 8
11	Stopper Pin	MILD STEEL	1
12	LOTO Clamp Bolts	SS 304	2
13	LOTO Clamp	SS 304	1
14	Gland Cover	ASTM A 351 GR. CF8	1
15	Plain Washer For Gland Cover	SS 304	2
16	Allen Bolt for Gland Cover	SS 304	2
17	Plain Washer For Handle	SS 304	1
18	Hex Bolt For Handle	SS 304	1

### SECTIONAL VIEW

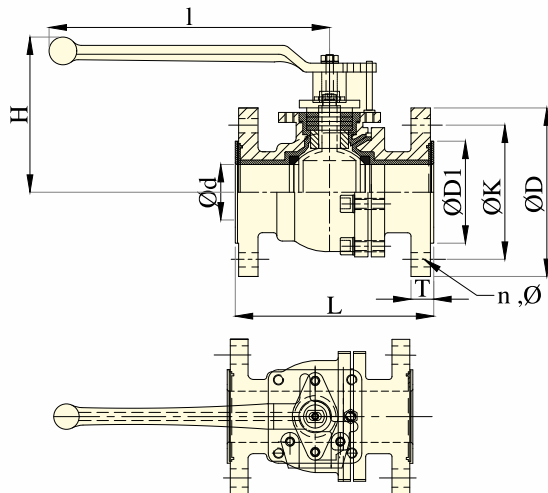

### DIMENSIONS

Size	Ød ±0.04		L ±0.12		ØD ±0.04		ØD1 ±0.04		T +0.11/-0.00		H (Approx)		ØK ±0.062		n	Ø ±0.02		l ±0.08	
	INCH	MM	INCH	MM	INCH	MM	INCH	MM	INCH	MM	INCH	MM	INCH	MM		INCH	MM	INCH	MM
0.5"	0.511	13	5.118	130	3.503	89	1.377	35	0.551	14	4.409	112	2.362	60	04	0.629	16	7.007	178
0.75"	0.787	20	5.905	150	3.858	98	1.692	43	0.551	14	4.763	121	2.755	70	04	0.629	16	7.007	178
1"	0.987	25	5.000	127	4.251	108	2.007	51	0.669	17	4.763	121	3.110	79	04	0.629	16	7.007	178
1.5"	1.574	40	6.496	165	5.000	127	2.874	73	0.748	19	5.354	136	3.858	98	04	0.629	16	10.000	254
2"	1.968	50	7.007	178	5.984	152	3.622	92	0.807	20.5	5.472	139	4.763	121	04	0.748	19	10.000	254
2.5"	2.559	65	7.480	190	7.007	178	4.133	105	0.885	23	6.692	168	5.511	140	04	0.748	19	12.007	305
3"	2.952	75	7.992	203	7.519	191	5.00	127	0.984	25	6.968	177	5.984	152	04	0.748	19	12.007	305
4"	3.937	100	9.015	229	9.015	229	6.181	157	0.984	25	8.110	206	7.519	191	08	0.748	19	12.007	305

### GEAR OPERATED

Size	Ød ±0.04		L ±0.12		ØD ±0.04		ØD1 ±0.04		T +0.11/-0.00		H (Approx)		ØK ±0.062		n	Ø ±0.02	
	INCH	MM	INCH	MM	INCH	MM	INCH	MM	INCH	MM	INCH	MM	INCH	MM		INCH	MM
6"	5.905	150	10.511	267	11.023	280	8.503	216	1.102	28	16.141	410	9.488	241	08	0.866	22

All Dimensions are in Inches & mm unless otherwise specified.  
 Tolerances are given in Inches.  
 • End to End Dimensions are as per ANSI B16. 10 short  
 \* Gear Operated

# PFA LINED BALL VALVE

## SIDE SPLIT - FULL PORT - LEVER OPERATED - DIN

### PART LIST

PART NO.	DESCRIPTION	MATERIAL OF CONSTRUCTION	QTY.
1	Body	ASTM A 216 GR. WCB + PFA LINED	1
2	Side Piece	ASTM A 216 GR. WCB + PFA LINED	1
3	Ball	CF8 INSTERTED PFA LINED	1
4	Stem Integral To Ball	CF8 + PFA LINED	1
5	Bush	PTFE	1
6	Handle	CS EPOXY PAINTED	1
7	Chevron	PTFE	3 - 6
8	Seat	PTFE	2
9	Allen Bolt For Body	ASTMA A 193 GR.B7	4 - 8
10	Allen Bolt Spring Washer	HT STEEL	4 - 8
11	Stopper Pin	STEEL	1
12	LOTO Clamp Bolts	SS 304	2
13	LOTO Clamp	SS 304	1
14	Gland Cover	ASTM A 351 GR. CF8	1
15	Spring Washer For Gland Cover	B7 / SS 304 / SS 316	2
16	Allen Bolt for Gland Cover	B7 / SS 304 / SS 316	2
17	Plain Washer For Handle	SS 304	1
18	Hex Bolt For Handle	SS 304	1

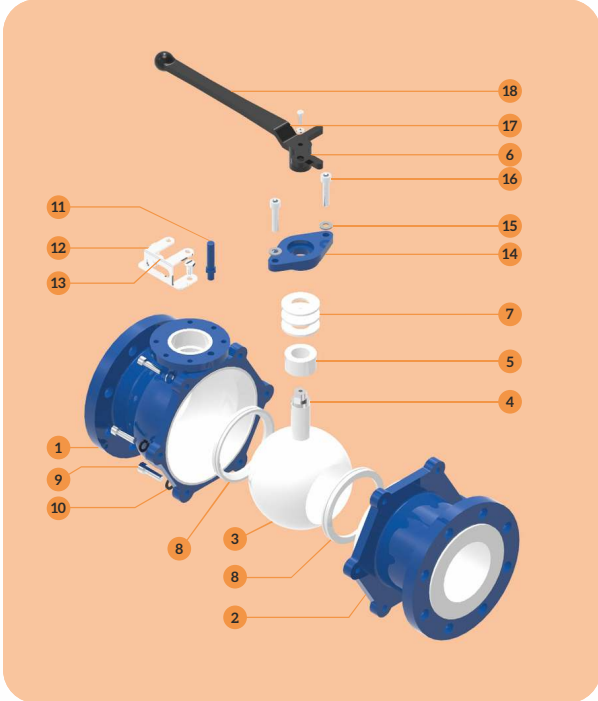

### SECTIONAL VIEW

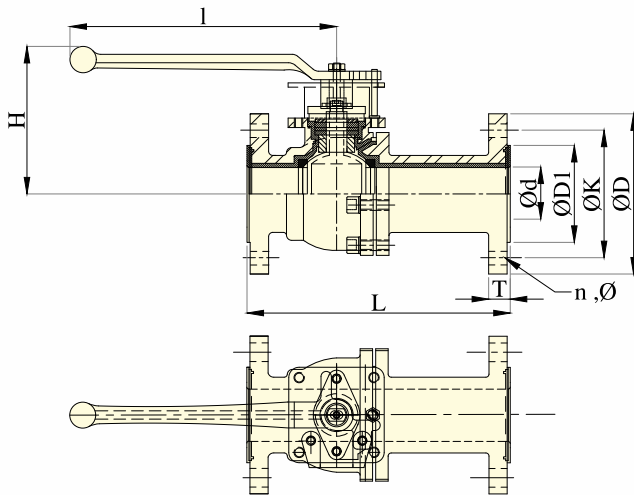

### DIMENSIONS

Size	Ød ±0.04		L ±0.12		ØD ±0.04		ØD1 ±0.04		T +0.11/-0.00		H (Approx)		ØK ±0.062		n	Ø ±0.02		l ±0.08	
	INCH	MM	INCH	MM	INCH	MM	INCH	MM	INCH	MM	INCH	MM	INCH	MM		INCH	MM	INCH	MM
0.5"	0.511	13	5.118	130	3.740	95	1.377	35	0.551	14	4.409	112	2.559	65	04	0.551	14	7.007	178
0.75	0.787	20	5.905	150	4.133	105	1.692	43	0.551	14	4.763	121	2.952	75	04	0.551	14	7.007	178
1"	0.9841	25	6.299	160	4.527	115	2.007	51	0.669	17	4.763	121	3.346	85	04	0.551	14	7.007	178
1.5"	1.574	40	7.874	200	5.905	150	2.874	73	0.748	19	5.354	136	4.330	110	04	0.708	18	10.000	254
2"	1.968	50	9.055	230	6.496	165	3.622	92	0.807	20.5	5.472	139	4.921	125	04	0.708	18	10.000	254
2.5"	2.559	65	11.417	290	7.283	185	4.133	105	0.885	22.5	6.692	170	5.708	145	04	0.708	18	12.007	305
3"	2.952	75	12.204	310	7.874	200	5.00	127	0.984	25	6.968	177	6.299	160	08	0.708	18	12.007	305
4"	3.937	100	13.779	350	8.661	220	6.181	157	0.984	25	8.110	206	7.086	180	08	0.708	18	12.007	305

### GEAR OPERATED

Size	Ød ±0.04		L ±0.12		ØD ±0.04		ØD1 ±0.04		T +0.11/-0.00		H (Approx)		ØK ±0.062		n	Ø ±0.02	
	INCH	MM	INCH	MM	INCH	MM	INCH	MM	INCH	MM	INCH	MM	INCH	MM		INCH	MM
6"	5.905	150	10.511	267	11.023	280	8.503	216	1.102	28	16.141	410	9.488	241	08	0.866	22

All Dimensions are in Inches & mm unless otherwise specified.  
Tolerances are given in Inches.  
• End to End Dimensions are as per DIN EN 558 - 1  
\* Gear Operated

# PFA LINED BALL VALVE

## CENTRE SPLIT - FULL PORT LEVER OPERATED

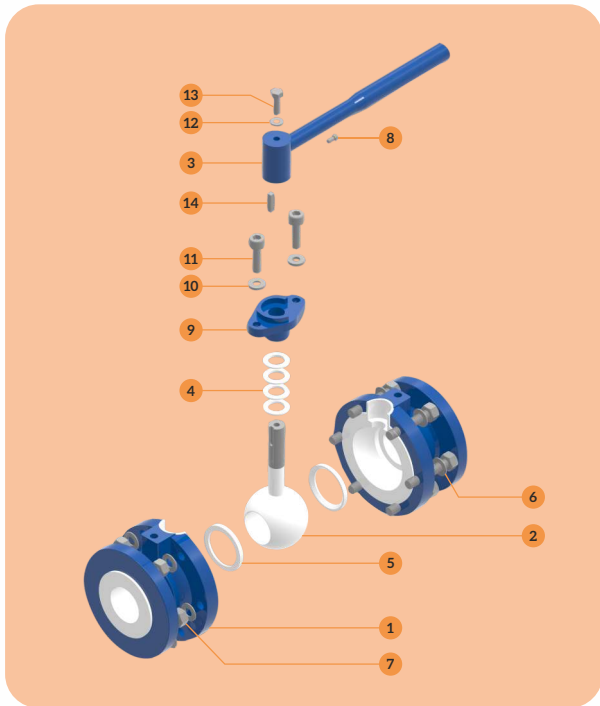

### PART LIST

PART NO.	DESCRIPTION	MATERIAL OF CONSTRUCTION	QTY.
1	Body	ASTM A 216 GR. WCB + PFA LINED	2
2	Ball With Integral Stem	CF8 INSERTED PFA LINED	1
3	Handle	CS EPOXY PAINTED	1
4	Chevron	PTFE	4 - 6
5	Seat	PTFE	2
6	Studs	ASTM A 193 GR. B7	4 - 10
7	Nuts	ASTM A 193 GR. 2H	8 - 20
8	Stopper Pin	ALEN BOLT HT 10.9	1
9	Gland Cover	ASTM A 216 GR. WCB	1
10	Plain Washer For Gland Cover	MS GALVANISED	2
11	Allen Bolt for Gland Cover	HT GRADE 10.9	2
12	Plain Washer for Handle	STEEL GALVANIZED	1
13	Hex Bolt For Handle	HT 10.9	1
14	Key For Handle	HT STEEL	1

### SECTIONAL VIEW

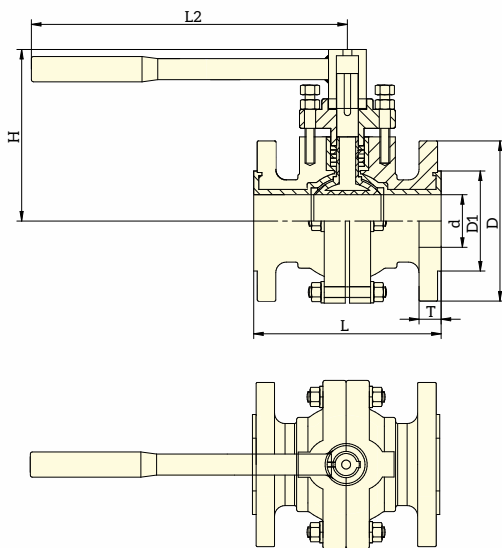

### DIMENSIONS

Size	L ±0.12		d ±0.04		D ±0.04		D1 ±0.08		L2 ±0.11		H (Approx)		T +0.11/-0.00		PCD ± 0.062		n	Ø ±0.02	
	INCH	MM	INCH	MM	INCH	MM	INCH	MM	INCH	MM	INCH	MM	INCH	MM	INCH	MM		INCH	MM
0.5"	4.25	108	0.51	13	3.50	89	1.38	35	7.87	200	4.33	110	0.55	14	2.36	60	04	5/8	16
0.75"	4.65	118	0.75	19	3.85	98	1.69	43	7.87	200	4.92	125	0.55	14	2.75	70	04	5/8	16
1"	5.00	127	0.94	25	4.25	108	2.00	51	7.87	200	4.92	125	0.63	16	3.10	79	04	5/8	16
1.5"	6.49	165	1.57	40	5.00	127	2.87	73	9.84	250	5.31	135	0.74	19	3.85	98	04	5/8	16
2"	7.00	178	1.96	50	5.98	152	3.62	92	12.20	310	6.30	160	0.80	20.50	4.76	121	04	3/4	19
2.5"	7.48	190	2.55	65	7.00	178	4.13	105	12.79	325	6.49	165	0.90	23	5.51	140	04	3/4	19
3"	7.99	203	2.95	75	7.51	191	5.00	127	12.79	325	6.89	175	0.98	25	5.98	152	04	3/4	19
4"	9.00	229	3.93	100	9.00	229	6.18	157	13.77	350	7.87	200	0.98	25	7.51	191	08	3/4	19
6"	10.50	267	5.90	150	11.00	280	8.50	216	19.68	500	12.20	310	1.10	28	9.48	241	08	7/8	22

All Dimensions are in Inches & mm unless otherwise specified. PCD of the Valve can be provided in ANSI / DIN / JIS. Tolerances are given in Inches.

# PFA LINED BALL VALVE

## CENTRE SPLIT - FULL PORT GEAR OPERATED

### PART LIST

PART NO.	DESCRIPTION	MATERIAL OF CONSTRUCTION	QTY.
1	Body	ASTM A 216 GR. WCB + PFA LINED	2
2	Ball With Integral Stem	CF8 INSERTED PFA LINED	1
3	Gear Box	CAST IRON EPOXY PAINTED	1
4	Chevron	PTFE	5
5	Seat	PTFE	2
6	Studs	ASTM A 193 GR. B7	12 - 16
7	Nuts	ASTM A 194 GR. 2H	24 - 32
8	Washers For Studs	STEEL	24 - 32
9	Gear Box Mounting Clamps	MS GALVANIZED / SS	2
10	Gear Box Clamp Allen Bolts	HT 10.9	4
11	Gland Cover	ASTM A 216 GR.WCB	1
12	Allen Bolt For Glad Cover	HT 10.9	4
13	Coupler Spindle / Gearbox	SS 304	1
14	Clamp Mounting Nuts	HT	4
15	Clamp Mounting Washers	HT	4

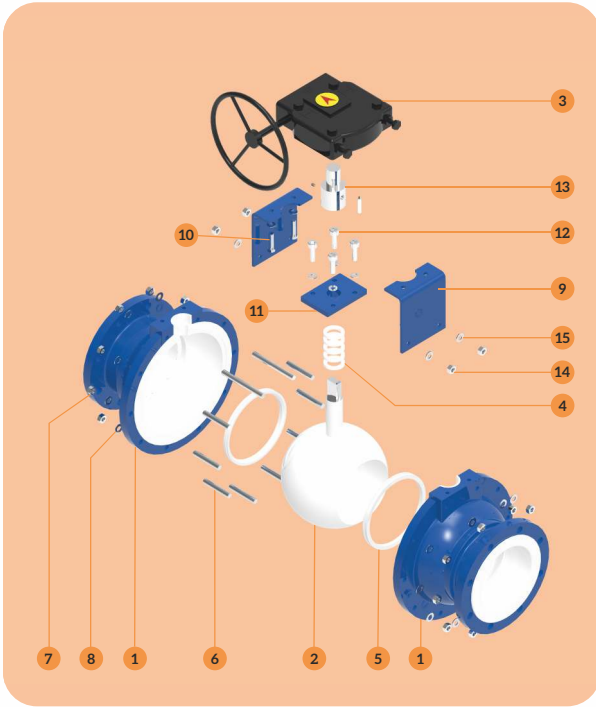

### SECTIONAL VIEW

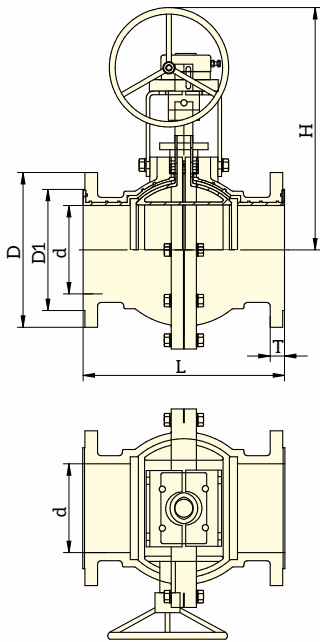

### DIMENSIONS

Size	L ±0.12		d ±0.04		D ±0.04		D1 ±0.08		H (Approx)		T +0.11 / -0.00		PCD ±0.062		n	Ø ± 0.02	
	INCH	MM	INCH	MM	INCH	MM	INCH	MM	INCH	MM	INCH	MM	INCH	MM		INCH	MM
8"	17.99	457	7.87	200	13.50	343	10.62	270	22.63	575	1.18	30	11.73	298	08	7/8	22
10"	20.98	533	9.84	250	15.98	406	12.75	324	24.60	625	1.29	33	14.25	362	12	1	25
12"	24.01	610	11.81	300	19.09	485	15.00	381	27.95	710	1.37	35	17.00	432	12	1	25

All Dimensions are in Inches & mm unless otherwise specified. PCD of the Valve can be provided in ANSI / DIN / JIS. Tolerances are given in Inches.

# PFA LINED BALL VALVE

## SIDE SPLIT - REDUCED PORT LEVER OPERATED



### PART LIST

PART NO.	DESCRIPTION	MATERIAL OF CONSTRUCTION	QTY.
1	Body	ASTM A 216 GR. WCB + PFA LINED	1
2	Side Piece	ASTM A 216 GR. WCB + PFA LINED	1
3	Ball	CF8 INSERTED PFA LINED	1
4	Spindle	CF8 INSERTED PFA LINED	1
5	Handle	CS EPOXY PAINTED	1
6	Chevron	PTFE	4 - 5
7	Seat	PTFE	2
8	Allen Bolt For Body	ASTM A 193 GR. B7	4
9	Plain Washer	HT STEEL	4
10	Locking Clamp	SS 304	1
11	Hex Bolt For Locking Clamp	SS 304	2
12	Stopper Pin	STEEL	1
13	Gland Cover	ASTM A 351 GR. CF8	1
14	Plain Washer for Gland Cover	SS 304	2
15	Allen Bolt for Gland Cover	SS 304	2
16	Hex Bolt For Handle	SS 304	1

### SECTIONAL VIEW

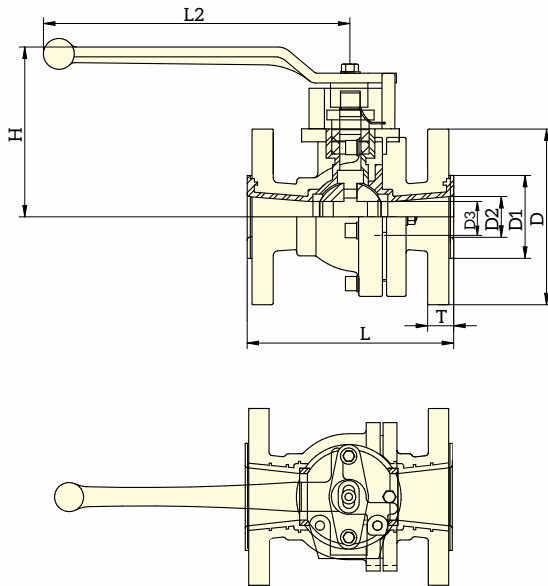

### DIMENSIONS

Size	L ±0.12		D2 ±0.04		D1 ±0.08		D ±0.04		L2 ±0.11		H (Approx)		T +0.11/-0.00		PCD ± 0.062		n	Ø ±0.02	
	INCH	MM	INCH	MM	INCH	MM	INCH	MM	INCH	MM	INCH	MM	INCH	MM	INCH	MM		INCH	MM
1"	5.00	127	0.94	25	2.00	51	4.25	108	7.00	178	4.76	121	0.67	17	3.10	79	04	5/8	16
1.5"	6.49	165	1.57	40	2.87	73	5.00	127	10.00	254	5.35	136	0.74	18.8	3.85	98	04	5/8	16
2"	7.00	178	1.96	50	3.62	92	5.98	152	10.00	254	5.47	139	0.81	20.5	4.76	121	04	3/4	19
3"	7.99	203	2.95	75	5.00	127	7.51	191	12.00	305	6.96	177	0.98	24.90	5.98	152	04	3/4	19
4"	9.00	229	3.93	100	6.18	157	9.00	229	12.00	305	8.11	206	0.98	24.90	7.51	191	08	3/4	19

All Dimensions are in Inches & mm unless otherwise specified. PCD of the Valve can be provided in ANSI / DIN / JIS. Tolerances are given in Inches.



# BALL VALVE FEATURES

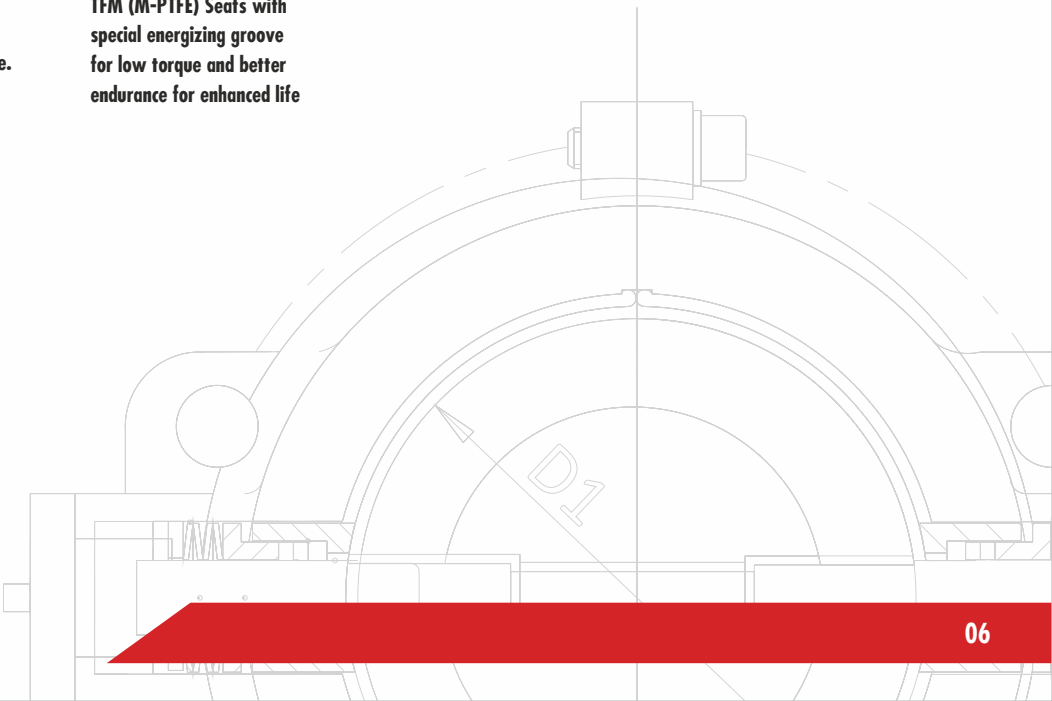
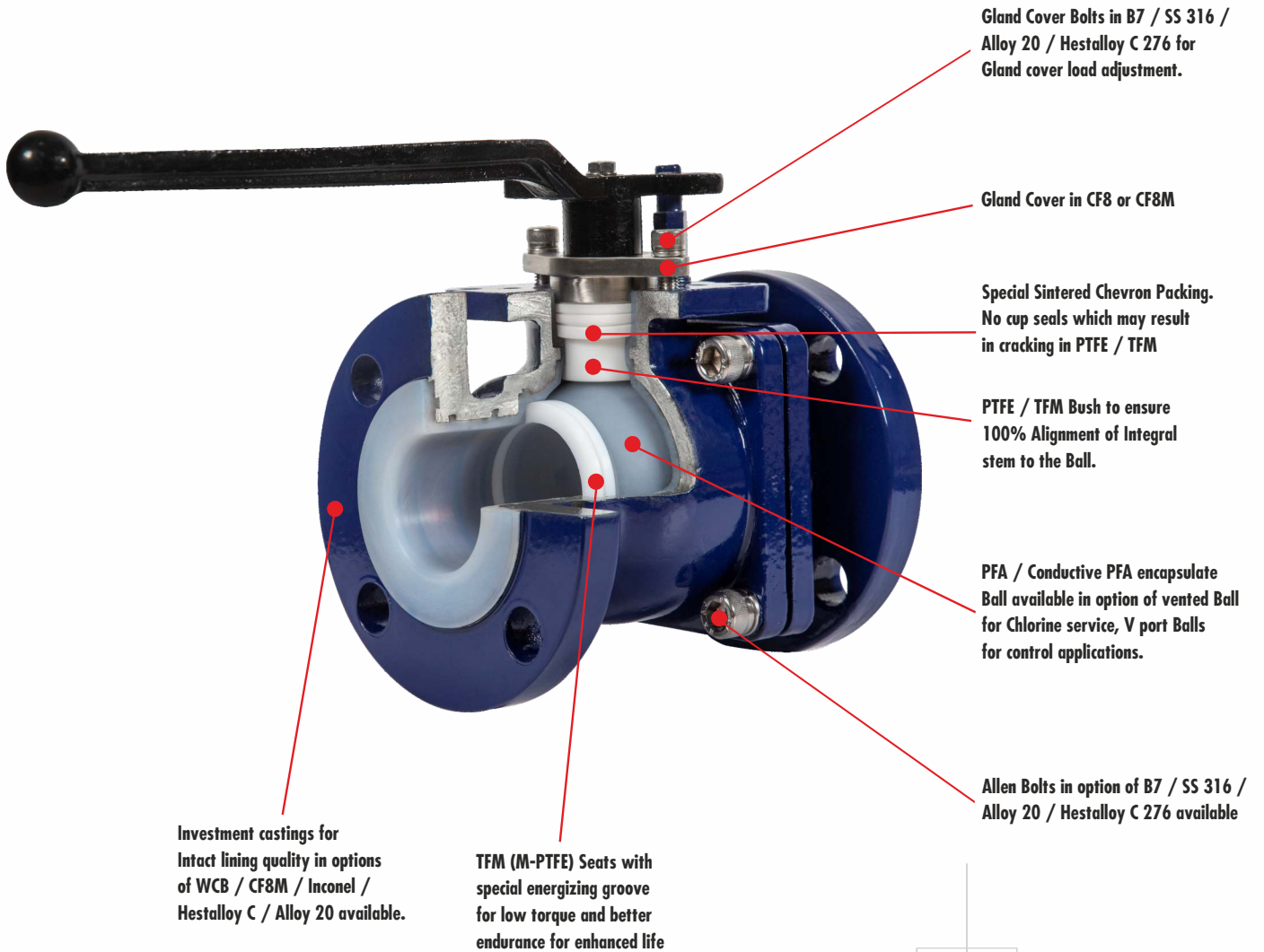

## PRODUCT DESIGN AND TESTS PERFORMED

DESIGN PARAMETERS	STANDARD
DESIGN STD	BS EN 17292
SHELL DESIGN	ANSI B 16.34
FLANGE CONNECTION RATING	ANSI B 16.5, 150# / DIN PN 10 / JIS
TESTING STANDARD	API 598 / BS EN 12266-1
CONNECTION	FLANGED, RF

TEST PERFORMED	API 598	API 598
SIZES	0.5" TO 4"	6" TO 12"
HIGH PR. SHELL TEST HYDRO	420 PSI	225 PSI
HIGH PR. SEAT TEST HYDRO	270 PSI	165 PSI
LOW PR. SEAT PNEUMATIC	105 PSI	75 PSI

SPARK TEST	KVDC
SPARK TEST	20 KVDC

## VALVE Cv & TORQUE VALUES

SIZE	Cv FULL PORT	Cv RED. PORT	TORQUE NM FULL PORT	TORQUE NM REDUCED PORT	TORQUE INCH-LBS FULL PORT	TORQUE INCH-LBS REDUCED PORT
0.5"	15	-	10	-	88	-
0.75"	25	-	12	-	106	-
1"	50	39	12	10	106	88
1.5"	185	50	20	18	177	159
2"	320	191	25	22	221	195
3"	805	330	40	35	354	310
4"	1600	790	65	50	575	443
6"	4500	-	180	-	1593	-
8"	8300	-	280	-	2478	-
10"	11725	-	350	-	3098	-
12"	18100	-	500	-	4425	-

TYPE	SIZE	STANDARD FOR END TO END DIM
FULL PORT SIDE SPLIT	1" - 6"	ANSI B 16.1 SHORT PATTERN
FULL PORT CENTRE SPLIT	8" - 12"	ANSI B 16.1 LONG PATTERN
FULL PORT SIDE SPLIT	1/2" & 3/4"	DIN EN 558 SERIES - 1
FULL PORT SIDE SPLIT	1/2" - 6"	DIN EN 558 SERIES - 1

## PRESSURE - TEMPERATURE GRAPH

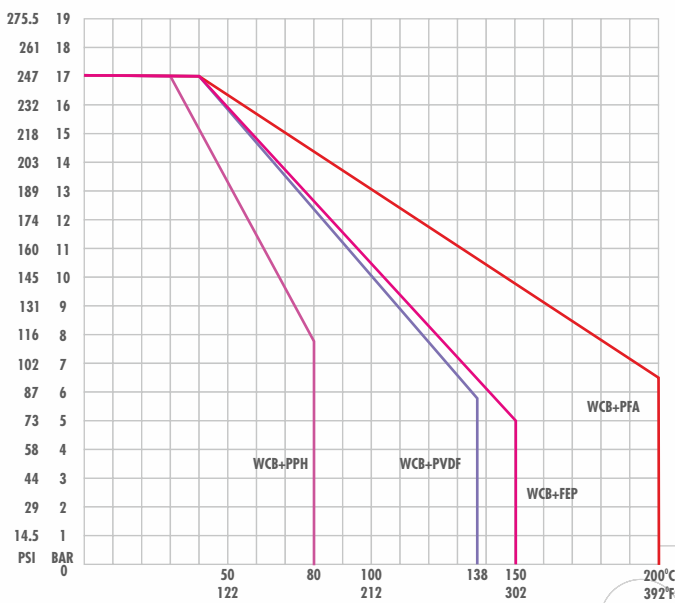

FOR 17 BAR ( 250 PSI )  
RATING VALVES

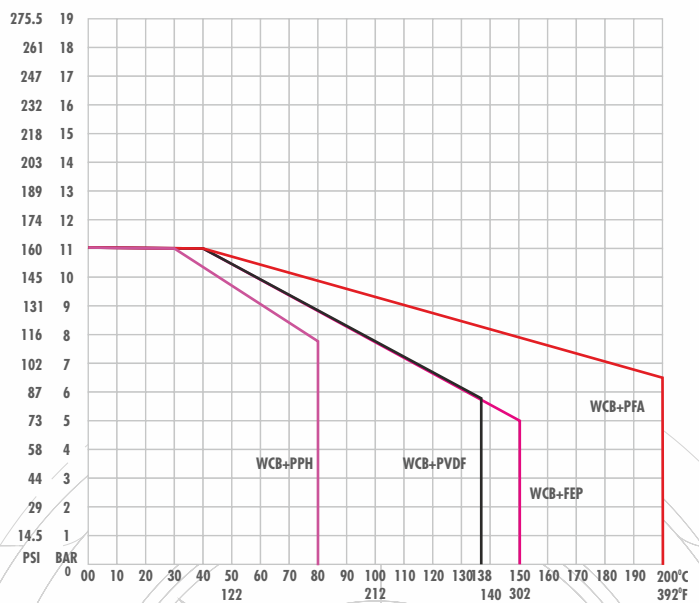

FOR 11 BAR ( 160 PSI )  
RATING VALVES

### VALVE CODE USED

TYPE OF VALVE	CODE
FULL PORT SIDE SPLIT BALL VALVE	BVFP
FULL PORT CENTRE SPLIT BALL VALVE	BVFP
REDUCED PORT SIDE SPLIT BALL VALVE	BVRP

BODY CASTING	CODE
ASTM A 216 GR. WCB	C1
ASTM A 351 GR. CF 8	C2
ASTM A 351 GR. CF8M	C3

TRIM INSERTS	CODE
ASTMA A 351 GR. CF8	T2
ASTM A 351 GR. CF8M	T3
ASTM A 890 GR. 4A(CD3MN)	T5

LINING MATERIAL	CODE
PFA	L1
FEP	L2
PVDF	L3
ETFE	L4
PPH	L6
ANTISTATIC PFA	L7

BODY BOLTS	CODE
SS 304	F2
SS 316	F3
HIGH TENSILE	F4
ASTM A 193 GR. B7	F5

OPERATION	CODE
LEVER	L
GEAR	G
BARE STEM	B

### VALVE CODE USED

LOCKING	CODE
PROVIDED	Y
NOT PROVIDED	N

SIZE											
0.5"	0.75"	1"	1.5"	2"	2.5"	3"	4"	6"	8"	10"	12"

CODE											
0H	75	01	1H	02	2H	03	04	06	08	10	12

### HOW TO READ CODE

CODE	BVFPCT3L1F5LY02	
VALVE TYPE	BALL VALVE FULL PORT	BVFP
BODY CASTING	ASTM A 216 GR.WCB	C1
TRIM INSERT	ASTM A 351 GR.CF8M	T3
LINING MATERIAL	PFA	L1
FASTNERS	ASTM A193 GR.B7	F5
OPERATION	LEVER	L
LOCKING ARRANGEMENT	PROVIDED	Y
VALVE SIZE	2"	02

### WEIGHT CHART / VALVE

SIZE	WT. IN KGS CENTRE SPLIT FULL PORT	WT. IN LBS CENTRE SPLIT FULL PORT	WT. IN KGS SIDE SPLIT FULL PORT (ANSI)	WT. IN LBS SIDE SPLIT FULL PORT (ANSI)	WT. IN KGS SIDE SPLIT FULL PORT (DIN)	WT. IN LBS SIDE SPLIT FULL PORT (DIN)	WT. IN KGS SIDE SPLIT REDUCED PORT	WT. IN LBS SIDE SPLIT REDUCED PORT
0.5"	3	7	3.00	7	3.00	7	-	-
0.75"	3.8	8.5	3.95	9	3.95	9	-	-
1"	4.5	10	4.50	10	4.90	11	4.2	9.25
1.5"	7.5	16.5	7.60	17	9.35	21	7.4	16
2"	12.2	27	10.40	23	11.95	26	11	24
2.5"	15	33	15.00	33	19.00	42	-	-
3"	21	46	20.00	44	23.45	52	19.5	43
4"	33	73	33.00	73	36.75	81	28	62
6"	65	143	60.00	132	70	154	-	-
8"	135	297	-	-	-	-	-	-
10"	206	453	-	-	-	-	-	-
12"	322	708	-	-	-	-	-	-

# CERTIFICATION

**TRANSPACIFIC CERTIFICATIONS LIMITED**



**Certificate of Registration**  
This is to certify that  
**Quality Management System**  
of  
**UNP POLYVALVES (INDIA) PVT. LTD.**  
5 to 12, P.S. Industrial Estate, P.O. GIDC - Keshavnagar Road,  
Kashipur, Vadodra - 391 243, Gujarat, India.



complies with the requirements of  
**ISO 9001:2015**  
This certificate is valid concerning all activities related to:  
Design, Manufacturing and Supply of Engineering Plastics and  
Lined Valves, Ball Check, Swing Check, Diaphragm, Butterfly,  
Plug Globe, Foot, Sight Glass, Sampling and Strainers for Corrosive and  
Aggressive Media in Chemical, Petrochemical, Steel, OGM  
Process and Pharmaceutical Industries.  
ANZSIC Code: 3912

14172  
Certificate No. Aug. 06, 2018 \*Next Audit Due Date  
Aug. 06, 2018 Date of Initial Registration Aug. 02, 2021 Certification Expiry Date  
Managing Director





**TRANSPACIFIC CERTIFICATIONS LIMITED**  
Website: www.transpacificcert.com Email: info@transpacificcert.com  
Headquarters: 100, 101, 102, 103, 104, 105, 106, 107, 108, 109, 110, 111, 112, 113, 114, 115, 116, 117, 118, 119, 120, 121, 122, 123, 124, 125, 126, 127, 128, 129, 130, 131, 132, 133, 134, 135, 136, 137, 138, 139, 140, 141, 142, 143, 144, 145, 146, 147, 148, 149, 150, 151, 152, 153, 154, 155, 156, 157, 158, 159, 160, 161, 162, 163, 164, 165, 166, 167, 168, 169, 170, 171, 172, 173, 174, 175, 176, 177, 178, 179, 180, 181, 182, 183, 184, 185, 186, 187, 188, 189, 190, 191, 192, 193, 194, 195, 196, 197, 198, 199, 200, 201, 202, 203, 204, 205, 206, 207, 208, 209, 210, 211, 212, 213, 214, 215, 216, 217, 218, 219, 220, 221, 222, 223, 224, 225, 226, 227, 228, 229, 230, 231, 232, 233, 234, 235, 236, 237, 238, 239, 240, 241, 242, 243, 244, 245, 246, 247, 248, 249, 250, 251, 252, 253, 254, 255, 256, 257, 258, 259, 260, 261, 262, 263, 264, 265, 266, 267, 268, 269, 270, 271, 272, 273, 274, 275, 276, 277, 278, 279, 280, 281, 282, 283, 284, 285, 286, 287, 288, 289, 290, 291, 292, 293, 294, 295, 296, 297, 298, 299, 300, 301, 302, 303, 304, 305, 306, 307, 308, 309, 310, 311, 312, 313, 314, 315, 316, 317, 318, 319, 320, 321, 322, 323, 324, 325, 326, 327, 328, 329, 330, 331, 332, 333, 334, 335, 336, 337, 338, 339, 340, 341, 342, 343, 344, 345, 346, 347, 348, 349, 350, 351, 352, 353, 354, 355, 356, 357, 358, 359, 360, 361, 362, 363, 364, 365, 366, 367, 368, 369, 370, 371, 372, 373, 374, 375, 376, 377, 378, 379, 380, 381, 382, 383, 384, 385, 386, 387, 388, 389, 390, 391, 392, 393, 394, 395, 396, 397, 398, 399, 400, 401, 402, 403, 404, 405, 406, 407, 408, 409, 410, 411, 412, 413, 414, 415, 416, 417, 418, 419, 420, 421, 422, 423, 424, 425, 426, 427, 428, 429, 430, 431, 432, 433, 434, 435, 436, 437, 438, 439, 440, 441, 442, 443, 444, 445, 446, 447, 448, 449, 450, 451, 452, 453, 454, 455, 456, 457, 458, 459, 460, 461, 462, 463, 464, 465, 466, 467, 468, 469, 470, 471, 472, 473, 474, 475, 476, 477, 478, 479, 480, 481, 482, 483, 484, 485, 486, 487, 488, 489, 490, 491, 492, 493, 494, 495, 496, 497, 498, 499, 500, 501, 502, 503, 504, 505, 506, 507, 508, 509, 510, 511, 512, 513, 514, 515, 516, 517, 518, 519, 520, 521, 522, 523, 524, 525, 526, 527, 528, 529, 530, 531, 532, 533, 534, 535, 536, 537, 538, 539, 540, 541, 542, 543, 544, 545, 546, 547, 548, 549, 550, 551, 552, 553, 554, 555, 556, 557, 558, 559, 560, 561, 562, 563, 564, 565, 566, 567, 568, 569, 570, 571, 572, 573, 574, 575, 576, 577, 578, 579, 580, 581, 582, 583, 584, 585, 586, 587, 588, 589, 590, 591, 592, 593, 594, 595, 596, 597, 598, 599, 600, 601, 602, 603, 604, 605, 606, 607, 608, 609, 610, 611, 612, 613, 614, 615, 616, 617, 618, 619, 620, 621, 622, 623, 624, 625, 626, 627, 628, 629, 630, 631, 632, 633, 634, 635, 636, 637, 638, 639, 640, 641, 642, 643, 644, 645, 646, 647, 648, 649, 650, 651, 652, 653, 654, 655, 656, 657, 658, 659, 660, 661, 662, 663, 664, 665, 666, 667, 668, 669, 670, 671, 672, 673, 674, 675, 676, 677, 678, 679, 680, 681, 682, 683, 684, 685, 686, 687, 688, 689, 690, 691, 692, 693, 694, 695, 696, 697, 698, 699, 700, 701, 702, 703, 704, 705, 706, 707, 708, 709, 710, 711, 712, 713, 714, 715, 716, 717, 718, 719, 720, 721, 722, 723, 724, 725, 726, 727, 728, 729, 730, 731, 732, 733, 734, 735, 736, 737, 738, 739, 740, 741, 742, 743, 744, 745, 746, 747, 748, 749, 750, 751, 752, 753, 754, 755, 756, 757, 758, 759, 760, 761, 762, 763, 764, 765, 766, 767, 768, 769, 770, 771, 772, 773, 774, 775, 776, 777, 778, 779, 780, 781, 782, 783, 784, 785, 786, 787, 788, 789, 790, 791, 792, 793, 794, 795, 796, 797, 798, 799, 800, 801, 802, 803, 804, 805, 806, 807, 808, 809, 810, 811, 812, 813, 814, 815, 816, 817, 818, 819, 820, 821, 822, 823, 824, 825, 826, 827, 828, 829, 830, 831, 832, 833, 834, 835, 836, 837, 838, 839, 840, 841, 842, 843, 844, 845, 846, 847, 848, 849, 850, 851, 852, 853, 854, 855, 856, 857, 858, 859, 860, 861, 862, 863, 864, 865, 866, 867, 868, 869, 870, 871, 872, 873, 874, 875, 876, 877, 878, 879, 880, 881, 882, 883, 884, 885, 886, 887, 888, 889, 890, 891, 892, 893, 894, 895, 896, 897, 898, 899, 900, 901, 902, 903, 904, 905, 906, 907, 908, 909, 910, 911, 912, 913, 914, 915, 916, 917, 918, 919, 920, 921, 922, 923, 924, 925, 926, 927, 928, 929, 930, 931, 932, 933, 934, 935, 936, 937, 938, 939, 940, 941, 942, 943, 944, 945, 946, 947, 948, 949, 950, 951, 952, 953, 954, 955, 956, 957, 958, 959, 960, 961, 962, 963, 964, 965, 966, 967, 968, 969, 970, 971, 972, 973, 974, 975, 976, 977, 978, 979, 980, 981, 982, 983, 984, 985, 986, 987, 988, 989, 990, 991, 992, 993, 994, 995, 996, 997, 998, 999, 1000.



**TECHNICKÁ INŠPEKCIA, a.s.**  
SLOVENSKÁ REPUBLIKA  
**CEOC**  
INTERNÁLE

**ACKNOWLEDGEMENT OF RECEIPT**  
no. 1342/1/2018

Technická inšpekcia, a.s.  
Trnavská cesta 68, 821 01 Bratislava  
Notified body 1504

confirms, that **Technical File Documentation**  
prepared by  
**UNP POLYVALVES (INDIA) PVT. LTD.**  
PLOT NO.3 TO 12 P.S. INDUSTRIAL ESTATE, P.O. GIDC - KASHIPUR ROAD,  
KASHIPURA, VODODARA-39143, GUJARAT, INDIA

has been received and stored according to the Article 13 (5b) of Directive no.  
2014/54/EU on equipment and protective systems intended for use in potentially explosive  
atmospheres.

Scope of the Equipment:  
**BALL VALVES, DIAPHRAGM VALVES, BUTTERFLY VALVES,  
PLUG VALVES, GLOBE VALVES**  
Type: **INDUSTRIAL VALVES**

Marking: **II 2 GO Ex n IIC T3 G0,  
Ex n IIC T200°C D0**

Technical File Documentation according to the Annex VIII Article 2 of Directive 2014/54/EU

Doc. no.	Reviz
UNP/TF/2018-01	DATE: 23.08.2018 REV: 00.00

Technical documentation will be stored for 10 years until May 7th, 2028.

On behalf of Technická inšpekcia, a.s.  
Ing. Dušan Perák  
General Director



EUROPEAN INSPECTION AND CERTIFICATION COMPANY S.A.

**CERTIFICATE OF FULL QUALITY ASSURANCE FOR PRESSURE EQUIPMENT**  
ACCORDING TO EUROPEAN DIRECTIVE 2014/68/EU (MODULE H)

CERTIFICATE NO. **14172**

THIS IS TO CERTIFY THAT **UNP POLYVALVES (INDIA) PVT. LTD.** HAS BEEN ASSESSED WITH SATISFACTORY RESULTS  
THE QUALITY ASSURANCE SYSTEM OF THE FOLLOWING MANUFACTURE:  
**UNP POLYVALVES (INDIA) PVT. LTD.**  
P.O. NO. 3 TO 12, P.S. INDUSTRIAL ESTATE, P.O. GIDC-KASHIPURA ROAD, KASHIPURA - 391433, VADODRA, GUJARAT, INDIA

\*CATEGORY OF PRESSURE EQUIPMENT:  
**INDUSTRIAL VALVES**

CATEGORY OF PRESSURE EQUIPMENT:  
**INDUSTRIAL VALVES**

AGAINST THE PROVISIONS OF:  
EUROPEAN PRESSURE EQUIPMENT DIRECTIVE  
2014/68/EU (MODULE H)

THIS CERTIFICATE IS VALID FOR THE FOLLOWING SCOPE:  
DESIGN, PRODUCTION FINAL INSPECTION AND TESTING OF PRESSURE EQUIPMENT

**CONDITIONS AND LIMITATIONS:**  
Each pressure equipment should be an appropriate reference of the manufacturer of conformity and instructions of use.  
The manufacturer must affix the appropriate reference of the notified certifier of the quality assurance system.  
The manufacturer must affix the CE Marking and Eurocert's Identification No. to each item of pressure equipment as stipulated below:

**CE 1128**

This Certificate is valid 10 (TEN) years subject to satisfactory annual surveillance.

AUDET REPORT NO.  
**PEM140046**

Ing. Dušan Perák  
General Director

EURO CERT  
CERTIFICATE OF FULL QUALITY ASSURANCE FOR PRESSURE EQUIPMENT

BY: CHASIS SIA & IACONS/ISSO, 144 22 METANOSSOS, ATHENS, GREECE  
Tel: +30 210 6222490, 30 210 6222492 Fax: +30 210 6222428  
Internet site: www.eurocert.gr e-mail: eurocert@eurocert.gr



EUROPEAN INSPECTION AND CERTIFICATION COMPANY S.A.

**TECHNICAL DESCRIPTION OF PRESSURE EQUIPMENT:**  
CERTIFICATE NO. **PEM140046**

NO	TYPE	DESCRIPTION	NOMINAL DIAMETER	PRESSURE RATING	TEST PRESSURE (KG/CM <sup>2</sup> )
1	WAFER	BUTTERFLY VALVES	DN 50 TO DN 350	PN 10	15
2	LUG	BUTTERFLY VALVES	DN 400	PN 10	15
3	LUG	BUTTERFLY VALVES	DN 450 TO DN 600	PN 06	09
4	BALL	CHECK VALVES	DN 25 TO DN 100	PN 10	15
5	BALL	CHECK VALVES	DN 150 TO DN 300	PN 06	09
6	WAFER	SWING CHECK VALVES	DN 80 TO DN 350	PN 10	15
7	WAFER & FLANGED	SAMPLING VALVES	DN 25	PN 04	06
8	WAFER	DIAPHRAGM VALVES	DN 15 TO DN 50	PN 10	15
9	WAFER	DIAPHRAGM VALVES	DN 65 TO DN 200	PN 06	09
10	FULL BORE	BALL VALVES	DN 15 TO DN 100	PN 10	15
11	FULL BORE	BALL VALVES	DN 150	PN 06	09
12	FULL BORE	BALL VALVES (OD)	DN 200 TO DN 300	PN 06	09
13	STRAIGHT	GLOBE VALVE	DN 15 TO DN 100	PN 10	15
14	SIDE SPLIT DESIGN, REGULAR	BALL VALVE	DN 25 TO DN 150	PN 10	15
15	SIDE SPLIT DESIGN, TAPERED	BALL VALVE	DN 25 TO DN 150	PN 10	15
16	FULL BORE	PLUG VALVE	DN 15 TO DN100	PN 10	15
17	TAPERED	PLUG VALVE (OD)	DN 150 TO DN200	PN 06	09

EURO CERT  
CERTIFICATE OF FULL QUALITY ASSURANCE FOR PRESSURE EQUIPMENT

BY: CHASIS SIA & IACONS/ISSO, 144 22 METANOSSOS, ATHENS, GREECE  
Tel: +30 210 6222490, 30 210 6222492 Fax: +30 210 6222428  
Internet site: www.eurocert.gr e-mail: eurocert@eurocert.gr

**APPROVED**  
**ISO 15848-1**  
FUGITIVE EMISSION CERTIFICATION  
**PFA LINED SIDE SPLIT**  
**FULL PORT BALL VALVES**  
Size Range : 1/2" to 6"

**APPROVED**  
**ISO 15848-1**  
FUGITIVE EMISSION CERTIFICATION  
**PFA LINED PLUG VALVES**  
Size Range : 1/2" to 8"

**APPROVED**  
**ISO 15848-1**  
FUGITIVE EMISSION CERTIFICATION  
**PFA LINED BUTTERFLY VALVE**  
Size Range : 2" to 24"

**APPROVED**  
**DIN EN 14432:2014**  
**PFA LINED BUTTERFLY VALVES**  
Size Range : 2" to 8"

**APPROVED**  
**DIN EN 14432:2014**  
**PFA LINED SIDE SPLIT**  
**DESIGN BALL VALVES**  
Size Range : 1" to 4"

**LIST OF CONSULTANT**







## VADODARA



### CORPORATE OFFICE

946, GIDC, Makarpura,  
Vadodara - 390 010. INDIA  
Phone : +91 - 265 - 2649248, 2632628  
Fax : +91 - 265 - 2637379  
Email : sales.baroda@polyvalve.com

### FACTORY

5 to 12 PR Industrial Estate,  
Por GIDC - Kashipura Road,  
Moje : Kashipura - 391 243,  
Dist. Vadodara. INDIA  
Phone : +91 70434 30467/77 , 70430 20707

## MUMBAI

### THANE

207, Orion Business Park, Next to Cine Max, Kapurbawdi,  
Ghodbunder Road, Thane (W) - 400 607. INDIA.  
Phone : +91 - 22 - 25896422, 25896524 / 25  
Fax : + 91 - 22 - 2589 - 4221  
Email : sales.thane@polyvalve.com

## USA



**DJK - Energy Houston**

### BRANCH OFFICE

DJK-ENERGY HOUSTON INC.  
13201, NW FWY, Suite 800,  
Houston, Texas - 77040, USA  
Phone : +1 832 213 9674  
Email : djk@linedvalvesamerica.us

[www.polyvalve.in](http://www.polyvalve.in) | [www.polyvalve.com](http://www.polyvalve.com)

- UNP Polyvalves reserves the right, without notice to alter or improve the designs, specifications, dimensions of the products described herein.
- UNP Polyvalves does not assume any responsibility for the data given in this brochure. It is necessary for the customers to carry out necessary tests before selecting the MOC for their applications.

## Distributor

**Authorised Dealer;**  
**PUSHKARNA SALES PVT LTD.**  
**4772. Hauz Qazi. Delhi-110006.**  
**Phones; 011-43675881/9818453355.**  
**Email; sales@pushkarnasales.com**  
**Site; www.pushkarnasales.com**

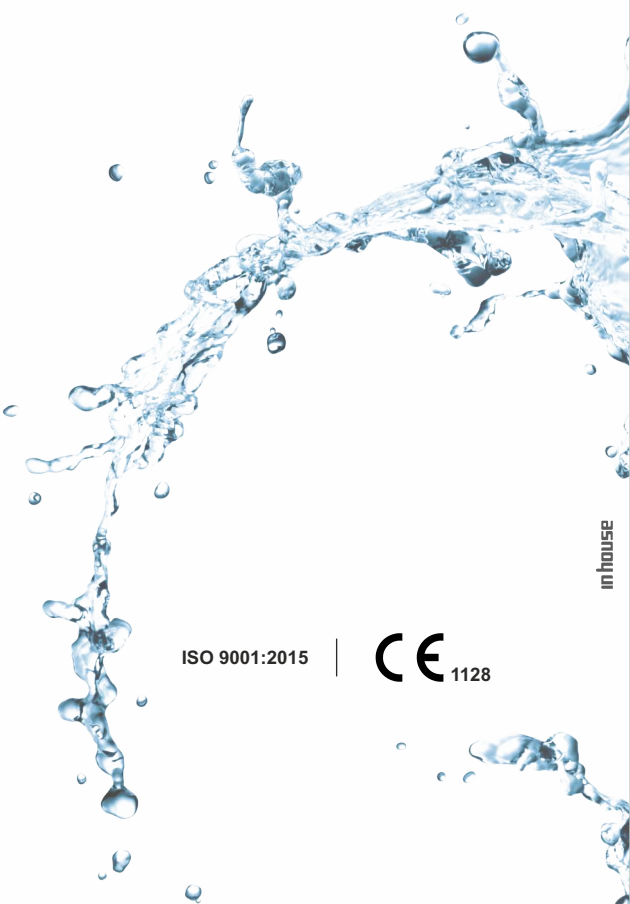

ISO 9001:2015

