



Type GTC

**Gate Valve
Cast Steel, Pressure seal Bonnet
Butt weld ends**

**2" - 24" (50-600 mm)
Class 900, 1500, 2500**

Design in accordance with ASME B16.34

Applications

- Power stations, general industry, process engineering
- For water, steam, gas, oil & other non-aggressive media
- Further applications on request

Operating Data

- Pressure up to 431 bar (6250 psi)
- Temperature up to +650°C / 1200°F
- Minimum temperature is 0°C (less than 0°C on request)
- Pressure-temperature ratings as per ASME B 16.34, Standard class

Materials

- ASTM A 216 WCB from 0°C to 425°C
- ASTM A 217 WC6/WC9 from 0°C to 593°C
- ASTM A 217 C12A from 0°C to 650°C

Design

- As per ASME B 16.34
- Pressure Seal Bonnet Design
- Stellite hard-faced Seats & Disc surface
- Graphite gaskets & packings with Braided wiping rings
- Internal pressure relieving on disc
- Direct retrofitting of Actuator
- Reduced bore
- Double disc wedge design

Variants on Request

- Bypass Arrangement
- Gear / Electrical Actuator
- Other pressure relief arrangements
- Full bore execution
- Position indicator
- Locking Arrangement
- Stem Protector
- Special class execution
- Other Material of construction

Remarks :

(Type Series Booklet References)

SICCA 800-2500 GTF / GLF / PCF	: 7240.1/12-11
SICCA 900-2500 GLC	: 7242.2/12-11
SICCA 900-2500 SCC	: 7243.2/12-11
SICCA 150-600 GTC	: 7244.2/12-11
SICCA 150-600 GLC	: 7245.2/12-11
SICCA 150-600 SCC	: 7246.2/12-11
Operating instructions no	: 0500.80/05-18 G3

On all enquiries / orders please specify :

1. Type
2. ASME Pressure class
3. Size
4. Design pressure/temperature
5. Operating pressure
6. Operating temperature
7. Differential pressure
8. Material of construction
9. Flow medium
10. Flow rate Min./Max.
11. Type of end connection
12. Pipe Schedule, ID / OD
13. Variants
14. Type Series Booklet no.
15. Valve data sheet (if applicable)

When ordering spares, indicate valve serial number.



**Authorised Dealer;
PUSHKARNA SALES PVT LTD.
4772. Hauz Qazi.Delhi-110006.
Phones;011-43675881/9818453355.
Email; sales@pushkarnasales.com
Site; www.pushkarnasales.com**



Product features to our customer benefit

- Stop Nut for Stroke Limitation.
- Stem Nut with thrust bearings enables Retrofitting of Actuators at Site.
- Burnished Stem. 13% Cr. (Hardened)
- Two Piece Self-Aligning Gland arrangement.
- Graphite Packing rings. Top & Bottom Ring - Braided.
- Spacer Ring - Prevent damage to Gasket.
- Seat ring - ST6 (HF), Seal Welded to Body
- Segmental Rings/ Thrust rings
- Graphite Gasket
- Bonnet
- Double Disc Gate arrangement.
- Pr. Relief Hole
- Seal Weld
- * Body

- Valves meets ASME B 16.34 requirements
- Unique Seat design ensures low operating torque
- Compact Yoke design ensures low valve weight
- Stop nut prevents over tightening of double disc gate
- Designed to retrofit valve with Actuator at site without disassembly of pressure retaining parts

Flow Direction →

Flow Seal

- Fully stellited Body & Disc seats
- Seat rings - seal welded to body
- Lapped Seat & Disc faces for leak tightness
- Streamlined flow path ensures minimum pressure drop

Disc Design

- Self aligning double disc arrangement ensures perfect seating
- Wedging action ensures leak tightness
- Leak tightness at low & high differential pressure
- Extended disc wear life by possibility of shim addition

Stem Wedge Connection

- Strong stem-disc joint capable of withstanding higher operating forces

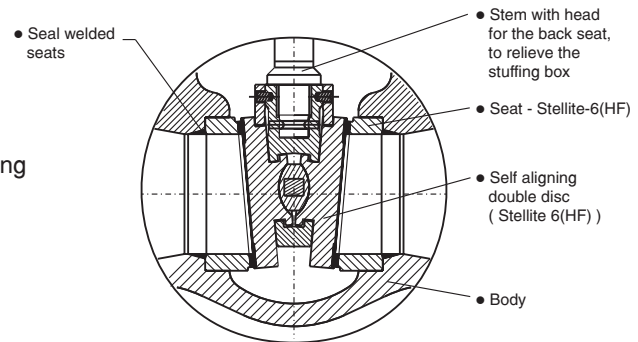

- Thrust ring
- Spacer ring
- Graphite gasket
- Body
- Bonnet
- Knock-out hole

Pressure Seal Bonnet

- Die moulded graphite gasket
- Segmental ring arrangement with knock out hole ensures easy disassembly

Retrofitting of Actuator & By-pass Execution

- Key
- Stem nut
- Stem
- By-Pass Valve
- X1
- X2

Mount Actuator with non-thrust base. Type 'E' or 'B' after removing handwheel.

- Self aligning gland
- Gland bush
- Braided Graphite (inconel reinforced) wiping rings at top & bottom
- Stem
- Integral Stellite-6 (HF) Backseat
- Die moulded Graphite rings

Gland Seal

- Die moulded graphite rings ensures effective sealing to atmosphere
- Top & bottom rings are braided graphite and inconel reinforced
- Braided rings offer smooth wiping action thereby arresting graphite depletion
- Smooth finished & polished stem and smooth stuffing box surfaces improve gland sealing life
- Two piece self aligning gland arrangement
- Integral hard faced back seat for maximum service life

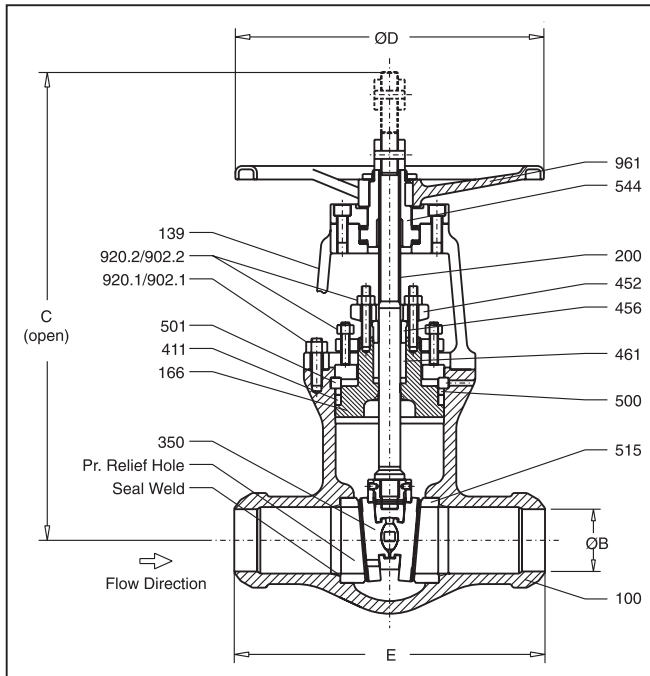

Design Specifications

General valve design & pressure, temperature rating : ASME B 16.34
 Butt weld end design : ASME B 16.25
 End to end dimension : ASME B 16.10
 Testing : API 598

Dimensions in mm

Class 900 RB

Size (in)	2"	3x2x3	4x3x4	6x4x6	8x6x8	10x8x10	12x10x12
E	215.9	304.8	355.6	508.0	660.4	787.4	914.4
ØB*	49.2	73.5	92.0	140.0	182.5	230.0	273.0
C _(max)	480.0	480.0	580.0	720.0	980.0	1200	1530
ØD	254.0	254.0	356.0	457.0	457.0	610.0	610.0

* Schedule 80 up to 3". Schedule 120 for 4" and above.
 Alternate schedule on request.

Class 1500 RB

Size (in)	3x2x3	4x3x4	6x4x6	8x6x8	10x8x10	12x10x12	14x12x14	16x14x16
E	304.8	406.4	558.8	711.2	863.6	990.6	990.6	1066.8
ØB*	66.5	87.5	132.0	173.0	216.0	257.0	284.0	325.5
C _(max)	530.0	595.0	740.0	1040	1230	1440	1850	1960
ØD	254.0	356.0	457.0	610.0	610.0	610.0	**	**

* Schedule 160. Alternate schedule on request.

Class 2500 RB

Size (in)	3x2x3	4x3x4	6x4x6	8x6x8	10x8x10	12x10x12
E	368.3	457.2	609.6	762.0	914.4	1041.4
ØB*	58.5	80.0	124.5	173.0	216.0	257.0
C _(max)	540.0	650.0	810.0	1030	1530	1580
ØD	254.0	457.0	508.0	610.0	**	**

* Schedule XXS up to 6". Schedule 160 for 8" and above.
 Alternate schedule on request. ** - mandatory Gear Box

Class 1500 FB

Size (in)	2"	3"	4"	6"	8"	10"	12"
E	215.9	304.8	406.4	558.8	711.2	863.6	990.6
ØB*	42.8	66.5	87.5	132.0	173.0	216.0	257.0
C _(max)	550.0	595.0	740.0	1040	1230	1440	1810
ØD	254.0	356.0	457.0	610.0	610.0	610.0	**

* Schedule 160
 Alternate schedule on request. ** - mandatory Gear Box

Class 2500 FB

Size (in)	2"	3"	4"	6"	8"	10"	12"
E	279.4	368.3	457.2	609.6	762.0	914.4	1041.4
ØB*	38.0	58.5	80.0	124.5	173.0	216.0	257.0
C _(max)	550.0	670.0	780.0	1050	1530	1580	1970
ØD	254.0	457.0	508.0	610.0	**	**	**

* Schedule XXS up to 6". Schedule 160 for 8" and above.
 Alternate schedule on request. ** - mandatory Gear Box

For details of higher size valves refer to P & A Coimbatore

Materials

Part No.	Description	Material			
100	Body	A 216-WCB	A 217-WC9	A 217-WC6	A217-C12A
139	Yoke	A 216-WCB	A 216-WCB	A 216-WCB	A216-WCB / A217 WC9
166	Bonnet *	A 216-WCB+ST6	A 217-WC9+ST6	A 217-WC6+ST6	A217-C12A+ST6
200	Stem	A 479-410-2	A 479-410-2	A 479-410-2	ASTM A 638-660
350	Disc	A 216-WCB+ST6	A 217-WC9+ST6	A 217-WC9+ST6	A182-F91+ST6 / A217-C12A+ST6
411	Gasket	Graphite	Graphite	Graphite	Graphite
452	Gland Flange	A 216-WCB	A 216-WCB	A 216-WCB	IS 2002-2(A 516-60)
456	Gland Bush	A 276-410	A 276-410	A 276-410	A 182-F22
461	Gland packing	Graphite	Graphite	Graphite	Graphite
500	Spacer ring	A 217-CA15 / A 182-F22	A 217-CA15 / A 182-F22	A 217-CA15 / A 182-F22	A217-CA15 / A182-F22
501	Thrust ring	A 182- F22	A 182-F22	A 182-F22	A182-F22
515	Seat Ring	A 105 + ST6	A 217-WC9+ST6 / A 182-F22+ST6	A 217-WC9+ST6 / A182-F22+ST6	A217-C12A / A182-F91+ST6
544	Stem Nut	Al. Bronze	Al. Bronze	Al. Bronze	Al. Bronze
902.1/902.2	Stud	A 193-B7	A 193-B16	A 193-B16	A193-B16
920.1/920.2	Hex. Nut	A 194-2H	A 194-4 / 7	A 194-4 / 7	A194-4/7
961	Hand wheel	SG IRON / CS	SG IRON / CS	SG IRON / CS	SG IRON / CS

Integral Bonnet back seat St6 (HF)

Testing

Test / Test pressure	# 900		#1500		# 2500		Testing medium
	kg/cm ²	psi	kg/cm ²	psi	kg/cm ²	psi	
Shell	238	3375	396	5625	660	9375	Water
Seat / Back Seat	174	2475	291	4125	484	6875	
Seat	4 to 7	58 to 100	4 to 7	58 to 100	4 to 7	58 to 100	Air

Pressure Temperature Rating - Standard Class
Rating for Group 1.1 Material : A 216 Gr. WCB ⁽¹⁾

Temperature		# 900		# 1500		# 2500	
°F	°C	PSI	Kg/cm ²	PSI	Kg/cm ²	PSI	Kg/cm ²
-20 to 100	-29 to 38	2220.0	156.1	3705.0	260.5	6170.0	433.8
200	93.3	2035.0	143.1	3395.0	238.7	5655.0	397.6
300	148.9	1965.0	138.2	3270.0	229.9	5450.0	383.2
400	204.4	1900.0	133.6	3170.0	222.9	5280.0	371.2
500	260.0	1810.0	127.3	3015.0	212.0	5025.0	353.3
600	315.6	1705.0	119.9	2840.0	199.7	4730.0	332.6
650	343.3	1650.0	116.0	2745.0	193.0	4575.0	321.7
700	371.1	1590.0	111.8	2665.0	187.4	4425.0	311.1
750	398.9	1520.0	106.9	2535.0	178.2	4230.0	297.4
800	426.7	1235.0	86.8	2055.0	144.5	3430.0	241.2
850	454.4	955.0	67.1	1595.0	112.1	2655.0	186.7
900	482.2	690.0	48.5	1150.0	80.9	1915.0	134.6
950	510.0	410.0	28.8	685.0	48.2	1145.0	80.5
1000	537.8	255.0	17.9	430.0	30.2	715.0	50.3

1) Permissible, but not recommended for prolonged use above 800°F

Rating for Group 1.9 Material : A 217 Gr. WC6 ^{(1) (2)}

Temperature		# 900		# 1500		# 2500	
°F	°C	PSI	Kg/cm ²	PSI	Kg/cm ²	PSI	Kg/cm ²
-20 to 100	-29 to 38	2250.0	158.2	3750.0	263.7	6250.0	439.4
200	93.3	2250.0	158.2	3750.0	263.7	6250.0	439.4
300	148.9	2165.0	152.2	3610.0	253.8	6015.0	422.9
400	204.4	2080.0	146.2	3465.0	243.6	5775.0	406.0
500	260.0	1995.0	140.3	3325.0	233.8	5540.0	389.5
600	315.6	1815.0	127.6	3025.0	212.7	5040.0	354.3
650	343.3	1765.0	124.1	2940.0	206.7	4905.0	344.9
700	371.1	1705.0	119.9	2840.0	199.7	4730.0	332.6
750	398.9	1595.0	112.1	2660.0	187.0	4430.0	311.5
800	426.7	1525.0	107.2	2540.0	178.6	4230.0	297.4
850	454.4	1460.0	102.6	2435.0	171.2	4060.0	285.4
900	482.2	1350.0	94.9	2245.0	157.8	3745.0	263.3
950	510.0	955.0	67.1	1595.0	112.1	2655.0	186.7
1000	537.8	650.0	45.7	1080.0	75.9	1800.0	126.6
1050	565.6	430.0	30.2	720.0	50.6	1200.0	84.4
1100	593.3	290.0	20.4	480.0	33.7	800.0	56.2
1150	621.1	195.0	13.7	325.0	22.8	545.0	38.3
1200	648.9	125.0	8.8	205.0	14.4	345.0	24.3

1) Use Normalised and tempered material only.

2) Not to be used over 1100°F

Rating for Group 1.10 Material : A 217 Gr. WC9 ^{(1) (2)}

Temperature		# 900		# 1500		# 2500	
°F	°C	PSI	Kg/cm ²	PSI	Kg/cm ²	PSI	Kg/cm ²
-20 to 100	-29 to 38	2250.0	158.2	3750.0	263.7	6250.0	439.4
200	93.3	2250.0	158.2	3750.0	263.7	6250.0	439.4
300	148.9	2185.0	153.6	3640.0	255.9	6070.0	426.8
400	204.4	2115.0	148.7	3530.0	248.2	5880.0	413.4
500	260.0	1995.0	140.3	3325.0	233.8	5540.0	389.5
600	315.6	1815.0	127.6	3025.0	212.7	5040.0	354.3
650	343.3	1765.0	124.1	2940.0	206.7	4905.0	344.9
700	371.1	1705.0	119.9	2840.0	199.7	4730.0	332.6
750	398.9	1595.0	112.1	2660.0	187.0	4430.0	311.5
800	426.7	1525.0	107.2	2540.0	178.6	4230.0	297.4
850	454.4	1460.0	102.6	2435.0	171.2	4060.0	285.4
900	482.2	1350.0	94.9	2245.0	157.8	3745.0	263.3
950	510.0	1160.0	81.6	1930.0	135.7	3220.0	226.4
1000	537.8	800.0	56.2	1335.0	93.9	2230.0	156.8
1050	565.6	525.0	36.9	875.0	61.5	1454.0	102.2
1100	593.3	330.0	23.2	550.0	38.7	915.0	64.3
1150	621.1	205.0	14.4	345.0	24.3	570.0	40.1
1200	648.9	125.0	8.8	205.0	14.4	345.0	24.3

1) Use Normalised and tempered material only.

2) Not to be used over 1100°F

Rating for Group 1.15 Material : A 217 Gr. C12A

Temperature		# 900		# 1500		# 2500	
°F	°C	PSI	Kg/cm ²	PSI	Kg/cm ²	PSI	Kg/cm ²
-20 to 100	-29 to 38	2250.0	158.2	3750.0	263.7	6250.0	439.4
200	93.3	2250.0	158.2	3750.0	263.7	6250.0	439.4
300	148.9	2185.0	153.6	3640.0	255.9	6070.0	426.8
400	204.4	2115.0	148.7	3530.0	248.2	5880.0	413.4
500	260.0	1995.0	140.3	3325.0	233.8	5540.0	389.5
600	315.6	1815.0	127.6	3025.0	212.7	5040.0	354.3
650	343.3	1765.0	124.1	2940.0	206.7	4905.0	344.9
700	371.1	1705.0	119.9	2840.0	199.7	4730.0	332.6
750	398.9	1595.0	112.1	2660.0	187.0	4430.0	311.5
800	426.7	1525.0	107.2	2540.0	178.6	4230.0	297.4
850	454.4	1460.0	102.6	2435.0	171.2	4060.0	285.4
900	482.2	1350.0	94.9	2245.0	157.8	3745.0	263.3
950	510.0	1160.0	81.6	1930.0	135.7	3220.0	226.4
1000	537.8	1090.0	76.6	1820.0	128.0	3030.0	213.0
1050	565.6	1080.0	75.9	1800.0	126.6	3000.0	210.9
1100	593.3	905.0	63.6	1510.0	106.2	2515.0	176.8
1150	621.1	670.0	47.1	1115.0	78.4	1855.0	130.4
1200	648.9	430.0	30.2	720.0	50.6	1200.0	84.4

Pressure Temperature Rating - Special Class

Rating for Group 1.1 Material : A 216 Gr. WCB ⁽¹⁾

Temperature		# 900		# 1500		# 2500	
°F	°C	PSI	Kg/cm ²	PSI	Kg/cm ²	PSI	Kg/cm ²
-20 to 100	-29 to 38	2250.0	158.2	3750.0	263.7	6250.0	439.4
200	93.3	2250.0	158.2	3750.0	263.7	6250.0	439.4
300	148.9	2220.0	156.1	3700.0	260.1	6170.0	439.4
400	204.4	2200.0	154.7	3665.0	257.7	6105.0	429.2
500	260.0	2200.0	154.7	3665.0	257.7	6105.0	429.2
600	315.6	2200.0	154.7	3665.0	257.7	6105.0	429.2
650	343.3	2145.0	150.8	3575.0	251.3	5960.0	419.0
700	371.1	2075.0	145.9	3455.0	242.9	5760.0	405.0
750	398.9	1905.0	133.9	3170.0	222.9	5285.0	371.6
800	426.7	1545.0	108.6	2570.0	180.7	4285.0	301.3
850	454.4	1195.0	84.0	1995.0	140.3	3320.0	233.4
900	482.2	860.0	60.5	1435.0	100.9	2395.0	168.4
950	510.0	515.0	36.2	855.0	60.1	1430.0	100.5
1000	537.8	320.0	22.5	535.0	37.6	895.0	62.9

1) Permissible, but not recommended for prolonged use above 800°F

Rating for Group 1.9 Material : A 217 Gr. WC6 ⁽¹⁾⁽²⁾

Temperature		# 900		# 1500		# 2500	
°F	°C	PSI	Kg/cm ²	PSI	Kg/cm ²	PSI	Kg/cm ²
-20 to 100	-29 to 38	2250.0	158.2	3750.0	263.7	6250.0	439.4
200	93.3	2250.0	158.2	3750.0	263.7	6250.0	439.4
300	148.9	2250.0	158.2	3750.0	263.7	6250.0	439.4
400	204.4	2250.0	158.2	3750.0	263.7	6250.0	439.4
500	260.0	2250.0	158.2	3750.0	263.7	6250.0	439.4
600	315.6	2250.0	158.2	3750.0	263.7	6250.0	439.4
650	343.3	2250.0	158.2	3750.0	263.7	6250.0	439.4
700	371.1	2200.0	154.7	3665.0	257.7	6110.0	429.6
750	398.9	2185.0	153.6	3645.0	256.3	6070.0	426.8
800	426.7	2160.0	151.9	3600.0	253.1	6000.0	421.8
850	454.4	2030.0	142.7	3385.0	238.0	5645.0	396.9
900	482.2	1760.0	123.7	2935.0	206.4	4895.0	344.2
950	510.0	1195.0	84.0	1995.0	140.3	3320.0	233.4
1000	537.8	810.0	56.9	1350.0	94.9	2250.0	158.2
1050	565.6	540.0	38.0	900.0	63.3	1500.0	105.5
1100	593.3	360.0	25.3	600.0	42.2	1000.0	70.3
1150	621.1	245.0	17.2	405.0	28.5	680.0	47.8
1200	648.9	155.0	10.9	255.0	17.9	430.0	30.2

1) Use Normalised and tempered material only.

2) Not to be used over 1100°F

Rating for Group 1.10 Material : A 217 Gr. WC9 ⁽¹⁾⁽²⁾

Temperature		# 900		# 1500		# 2500	
°F	°C	PSI	Kg/cm ²	PSI	Kg/cm ²	PSI	Kg/cm ²
-20 to 100	-29 to 38	2250.0	158.2	3750.0	263.7	6250.0	439.4
200	93.3	2250.0	158.2	3750.0	263.7	6250.0	439.4
300	148.9	2220.0	156.1	3695.0	259.8	6160.0	433.1
400	204.4	2185.0	153.6	3640.0	255.9	6065.0	426.4
500	260.0	2175.0	152.9	3620.0	254.5	6035.0	424.3
600	315.6	2165.0	152.2	3605.0	253.5	6010.0	422.5
650	343.3	2145.0	150.8	3580.0	251.7	5965.0	419.4
700	371.1	2120.0	149.1	3535.0	248.5	5895.0	414.5
750	398.9	2120.0	149.1	3535.0	248.5	5895.0	414.5
800	426.7	2120.0	149.1	3535.0	248.5	5895.0	414.5
850	454.4	2030.0	142.7	3385.0	238.0	5645.0	396.9
900	482.2	1800.0	126.6	3000.0	210.9	5000.0	351.5
950	510.0	1415.0	99.5	2360.0	165.9	3930.0	276.3
1000	537.8	1005.0	70.7	1670.0	117.4	2785.0	195.8
1050	565.6	655.0	46.1	1095.0	77.0	1820.0	128.0
1100	593.3	410.0	28.8	685.0	48.2	1145.0	80.5
1150	621.1	255.0	17.9	430.0	30.2	715.0	50.3
1200	648.9	155.0	10.9	255.0	17.9	430.0	30.2

1) Use Normalised and tempered material only.

2) Not to be used over 1100°F

Rating for Group 1.15 Material : A 217 Gr. C12A

Temperature		# 900		# 1500		# 2500	
°F	°C	PSI	Kg/cm ²	PSI	Kg/cm ²	PSI	Kg/cm ²
-20 to 100	-29 to 38	2250.0	158.2	3750.0	263.7	6250.0	439.4
200	93.3	2250.0	158.2	3750.0	263.7	6250.0	439.4
300	148.9	2250.0	158.2	3750.0	263.7	6250.0	439.4
400	204.4	2250.0	158.2	3750.0	263.7	6250.0	439.4
500	260.0	2250.0	158.2	3750.0	263.7	6250.0	439.4
600	315.6	2250.0	158.2	3750.0	263.7	6250.0	439.4
650	343.3	2250.0	158.2	3750.0	263.7	6250.0	439.4
700	371.1	2200.0	154.7	3665.0	257.7	6110.0	429.6
750	398.9	2185.0	153.6	3645.0	256.3	6070.0	426.8
800	426.7	2160.0	151.9	3600.0	253.1	6000.0	421.8
850	454.4	2030.0	142.7	3385.0	238.0	5645.0	396.9
900	482.2	1800.0	126.6	3000.0	210.9	5000.0	351.5
950	510.0	1415.0	99.5	2360.0	165.9	3930.0	276.3
1000	537.8	1260.0	88.6	2105.0	148.0	3505.0	246.4
1050	565.6	1260.0	88.6	2105.0	148.0	3505.0	246.4
1100	593.3	1130.0	79.4	1885.0	132.5	3145.0	221.1
1150	621.1	835.0	58.7	1395.0	98.1	2320.0	163.1
1200	648.9	540.0	38.0	900.0	63.3	1500.0	105.5