

## Forbes Marshall Spring-Loaded Disc Check Valve (Metal-to-Metal / Soft / Viton Seating)

*Authorised Dealer;*  
Pushkarna Sales Pvt Ltd.  
4772. Hauz Qazi. Delhi-06.  
Telefax : 011-23216378/23217239.  
Email : sales@pushkarnasales.com  
Web : www.pushkarnasales.com  
KSB, FORBES MARSHALL, BRAY,  
VAAS Valves & Automation.

### Description

The Forbes Marshall Spring - Loaded Disc Check Valve, FMDCV, is of the wafer pattern designed to be sandwiched between flanges. The FMDCV is suitable for use on a wide range of fluids for applications in process lines, Hot water systems, steam and condensate system etc. face-to-face dimensions conform to EN558 part 1 series 49

### Sizes and Pipe Connections

DN 15, 20, 32, 40, 50, 65, 80, 100 suitable for installation between PN 6, 10, 16, 25, 40

### Certification

Available with IBR  
All certification / inspection requirement must be stated at the time of order placement.

### Standard

Designed and manufactured in accordance with BS 7438

### Optional Extras

Heavy duty springs 700 m bar opening pressure up to DN 50 for boiler feed applications  
Viton soft seats for oil, gas and steam applications  
EPDM soft seats for water applications

### Limiting Conditions

Body design conditions		PN 40
PMO - Maximum operating pressure		40 bar g
TMO- Maximum Operating Temperature	Standard Spring	300°C
	Heavy duty spring	300°C
	Without spring	400°C
Minimum operating temperature (standard disc)		-10°C
Temperature Limits	Viton Seat	-10°C to +250°C
	EPDM Seat	-10°C to +150°C
Maximum cold hydraulic test pressure		80 bar g

### Operating Range

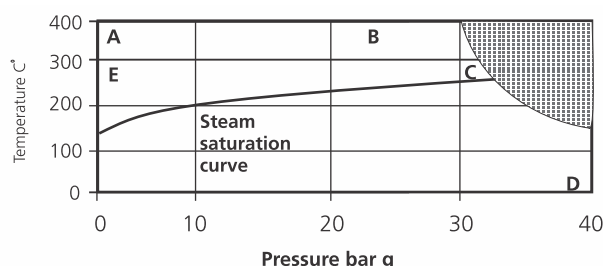

 The product must not be used in this region.  
E - C - D FMDCV with standard spring.  
A - B - D FMDCV without spring

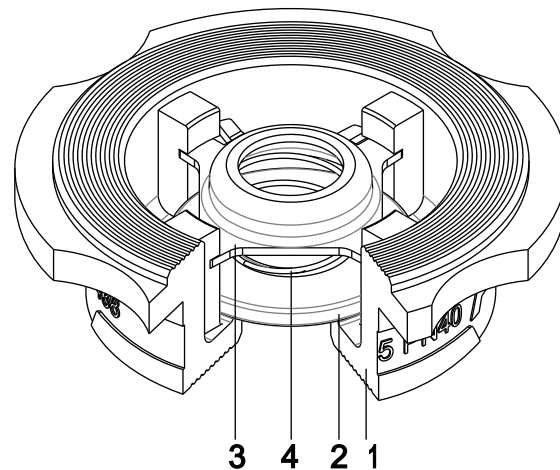

### Materials

No	Part	Material	Standard
1	Body	Austenitic stainless steel	ASTM A 351 CF8M
2	Disc	Austenitic stainless steel	ASTM A 351 CF3M
3	Spring retainer	Austenitic stainless steel	ASTM A 240 SS2316L
	Standard spring	Austenitic stainless steel	IS4454:IV:GR. 3 SS316
4	Heavy duty	Austenitic stainless steel	IS4454:IV:GR. 3 SS316

### Standard Shut-off

Standard valves conform to DIN 3230 part 3, BN2 Valves conforming to DIN 3230 part 3, BO3 available on request.

Soft seated versions meet DIN3230 part 3 BN 1 and BO1 provided a differential pressure exists.

### Operation

Forbes Marshall spring-loaded disc check valves are opened by the pressure of the fluid and closed by the spring as soon as flow ceases and before the reverse flow occurs.

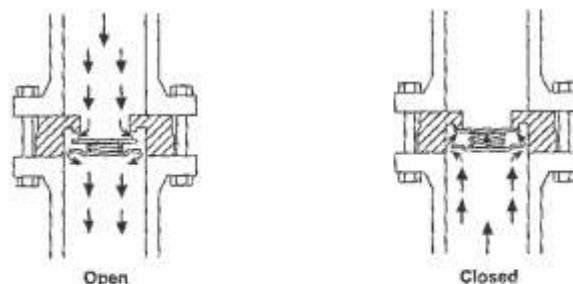

## Dimensions / Weights (approximate) in mm and kg

SIZE	A	B	C	D	E	F	G	Weight
DN15	60.0	45	43	38	16.0	29.0	15	0.13
DN20	69.5	55	53	45	19.0	35.7	20	0.19
DN25	80.5	65	63	55	22.0	44.0	25	0.32
DN32	84	78	75	68	28.0	54.5	32	0.53
DN40	101.0	88	85	79	31.5	65.5	40	0.74
DN50	115.0	98	95	93	40.0	77.0	50	1.25
DN65	129	118	115	113	46.0	97.5	65	1.84
DN80	154	134	133	128	50	111.5	80	2.42
DN100	184	154	154	148	60	130	100	3.81

### Kv Values

DN	15	20	25	32	40	50	65	80	100
Kv	4.4	6.8	10.8	17	26	43	60	80	113

For conversion : Cv (UK)=Kv x 0.963 Cv(US)=kv x 1.158

### Opening Pressures in mbar

Differential pressures with zero flow for standard and high temperature springs.

→ Flow direction

DN	15	20	25	32	40	50	65	80	100
↑	24	24	24	24	27	29	29	30	30
→	22	22	22	22	23	25	25	25	25
↓	19	19	19	19	19	19	19	19	19

Where lowest opening pressures are required, valves without springs can be installed in vertical pipes with bottom-to-top flow without spring

↑	2.5	2.5	3	3	4.0	4.5	4.5	5	6
---	-----	-----	---	---	-----	-----	-----	---	---

Heavy duty springs approximately 700 mbar

### Pressure Loss Diagram

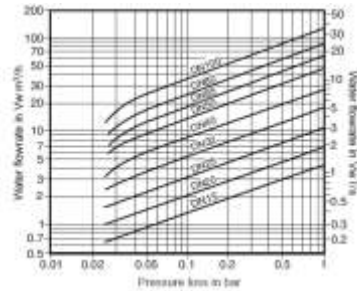

Pressure loss diagram with open valve at 20 °C. The valves indicated are applicable to spring loaded valves with horizontal flow. With vertical flow, insignificant deviations occur only within the range of partial opening.

The curves given in the chart are valid for water at 20 °C to determine the pressure for other fluids the equivalent water volume flowrate must be calculated and used in the graph.

$$V_w = \sqrt{\frac{r}{1000} \times V}$$

Where : V<sub>w</sub> = Equivalent water volume flow in l/s or m/h  
 r = Density of fluid kh/cm  
 V = Volume of fluid l/s or m/h

Pressure loss information for steam, compressed air and gases is available from Forbes Marshall.

### How to Order

Example : 1 No. Forbes Marshall spring loaded disk check valve DN 50 FMDCV (DIN) austenitic stainless steel for fitting between PN 40 flanges.

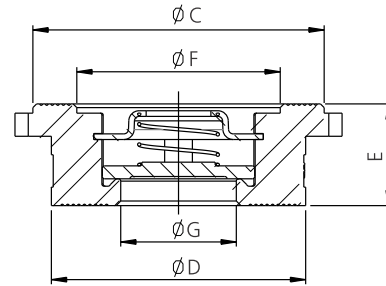
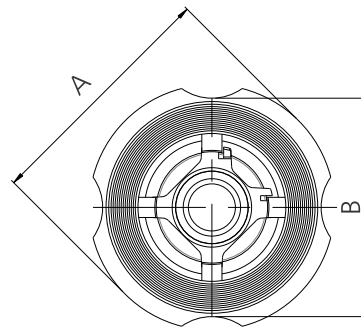

### Safety Information, Installation and Maintenance

For full details see the user manual supplied with the product. FMDCV spring loaded disc check valves must be fitted in accordance with the indicating correct fluid flow direction. When fitted with a spring they can be installed in any plane. When supplied without a spring they must be fitted in a vertical flow line with the flow from bottom-to-top.

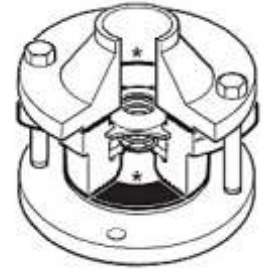

The 'cam' design of the body allows the various flange types to be accommodated. The body is rotated to touch the flange joint bolts ensuring that the valve is centered in the pipeline.

**Note :** Flanges, bolts (or studs), nuts and joint gaskets are to be provided by the installer. Forbes Marshall spring loaded disc check valves are non-maintainable (no spares are available) and are not suitable for use where heavily pulsating flow exists, such as close to a compressor.

### The available options are denoted by a marking on the valve body

W.	Without spring	Standard metal disc
H.	Heavy duty spring	Standard metal disc
'V'	Standard spring	Viton soft faced disc
'E'	Standard spring	EPDM soft faced disc
'WV'	Without spring	Viton soft faced disc
'WE'	Without spring	EPDM soft faced disc
'HV'	Heavy duty spring	Viton soft faced disc
'HE'	Heavy duty spring	EPDM soft faced disc
'T'	Valves tested to DIN 3230 part 3, B03	

**No identification** indicates a standard spring with a metal disc

### Disposal

If a product containing a viton component has been subjected to a temperature approaching 315 °C or higher, then it may have decomposed and formed hydrofluoric acid. Avoid skin contact and inhalation of any fumes as the acid will cause deep skin burns and damages to the respiratory system.